



US005888050A

United States Patent [19]
Fitzgerald et al.

[11] **Patent Number:** **5,888,050**
[45] **Date of Patent:** **Mar. 30, 1999**

[54] **PRECISION HIGH PRESSURE CONTROL ASSEMBLY**

[75] Inventors: **Wayne Fitzgerald**, Oxford, Pa.;
Kenneth J. James; Brian J. Waibel,
both of Newark, Del.

[73] Assignee: **Supercritical Fluid Technologies, Inc.**,
Newark, Del.

[21] Appl. No.: **139,230**

[22] Filed: **Aug. 25, 1998**

Related U.S. Application Data

[63] Continuation-in-part of Ser. No. 739,893, Oct. 30, 1996, Pat.
No. 5,797,719.

[51] **Int. Cl.⁶** **F04B 49/00**

[52] **U.S. Cl.** **417/46; 417/53; 62/50.6**

[58] **Field of Search** **417/46, 53; 62/50.6**

[56] **References Cited**

U.S. PATENT DOCUMENTS

3,972,654	8/1976	Clayton et al.	417/388
4,459,089	7/1984	Vincent et al.	417/383
4,681,678	7/1987	Leaseburge et al.	210/101
4,684,465	8/1987	Leaseburge et al.	

4,859,342	8/1989	Shirasawa et al.	210/656
5,240,603	8/1993	Frank et al.	210/198.2
5,252,041	10/1993	Schumack	417/46
5,269,930	12/1993	Jameson	
5,322,626	6/1994	Frank et al.	210/634
5,481,042	1/1996	Burba, III et al.	588/70

Primary Examiner—Charles G. Freay
Assistant Examiner—Ehud Gartenberg
Attorney, Agent, or Firm—Connolly & Hutz

[57] **ABSTRACT**

A precision high-pressure control assembly for supercritical fluids comprises a continuous flow system having a pressure control loop which includes a source of fluid communicating with a piston driven pump. A pressure sensor monitors the pressure of the supercritical fluid in the outlet line of the pump. A pressure controller has an input for receiving a signal relating to the pressure sent by the pressure sensor and the pressure controller yields an electronic output signal to an electropneumatic regulator. A source of air communicates with the electropneumatic regulator to provide pressurized regulated driver air directed to the pump. The electropneumatic regulator controls the regulated driver air pressure of the pump in accordance with the signal received from the pressure controller. The piston head of the pump is in a cryogenic chamber to minimize flash and cavitation.

14 Claims, 2 Drawing Sheets

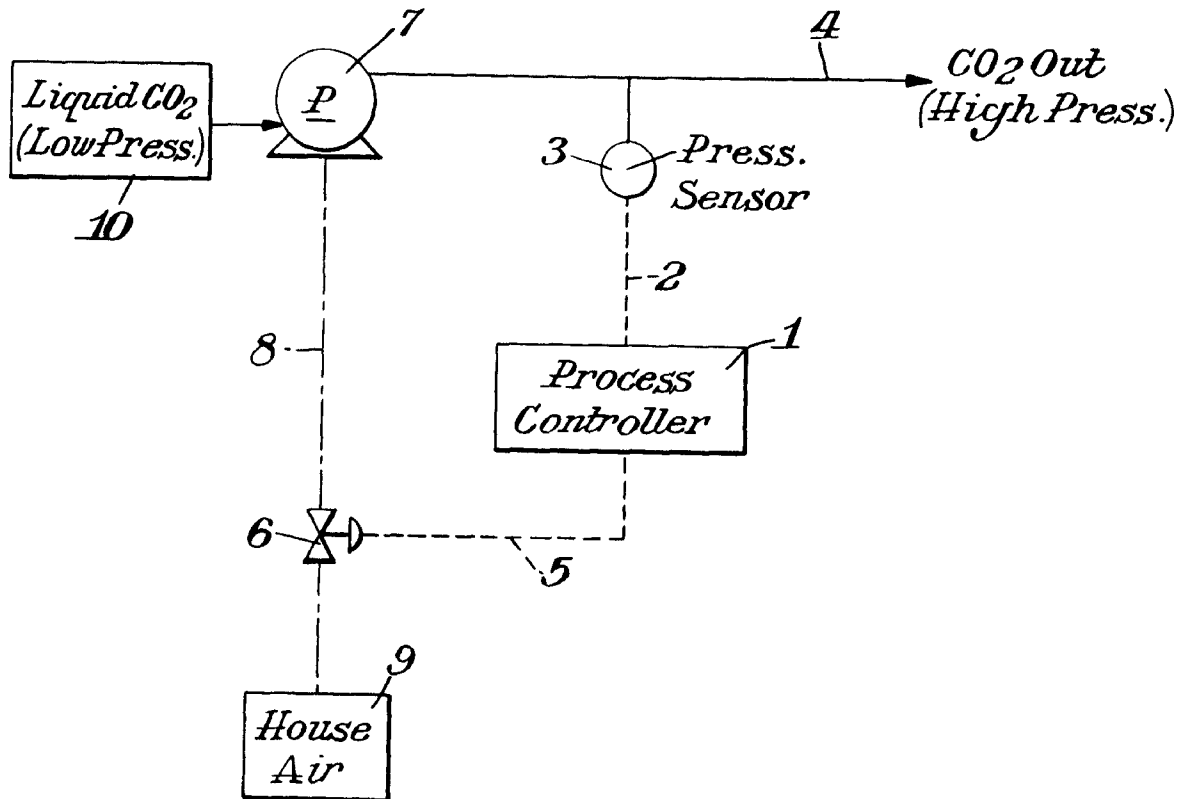

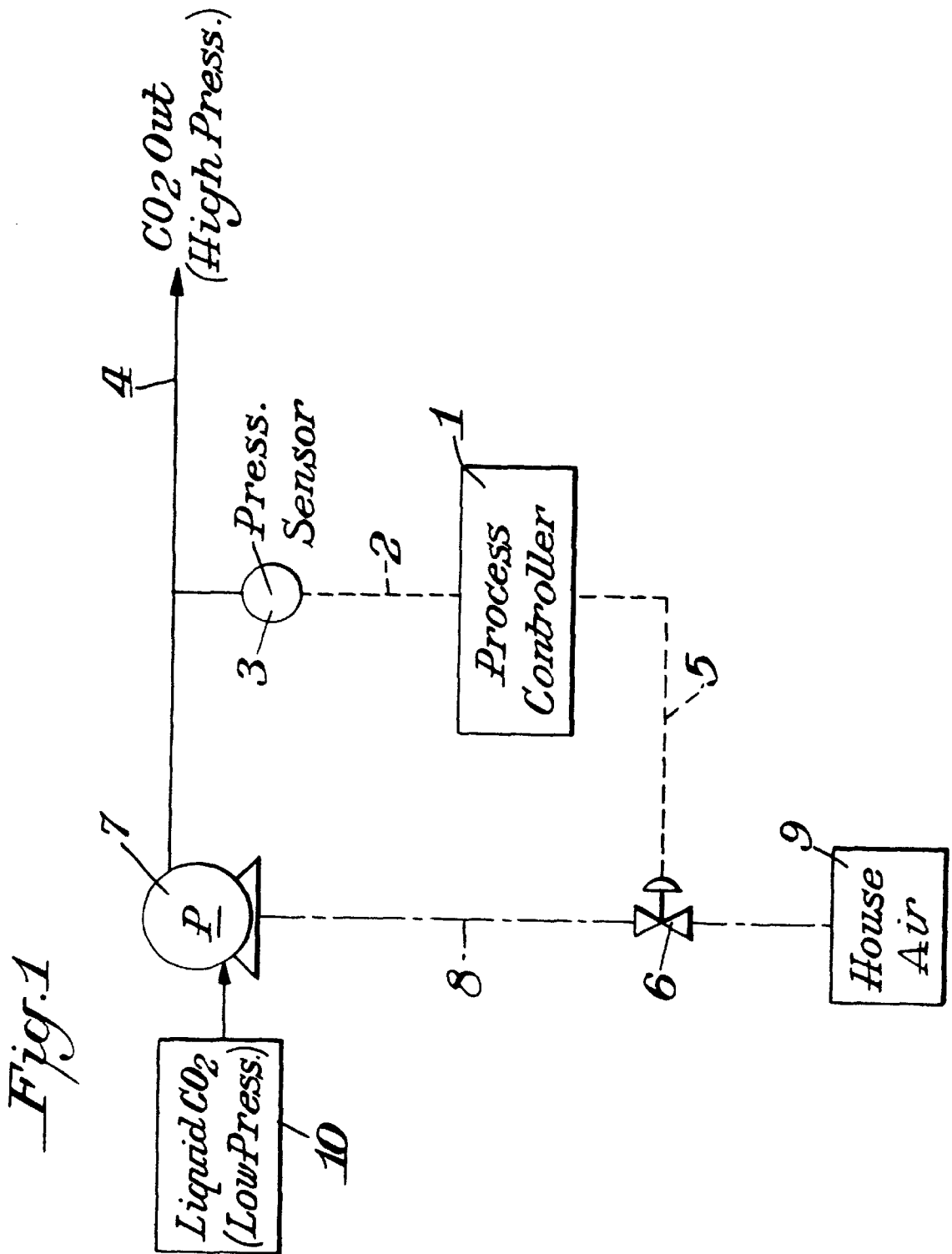
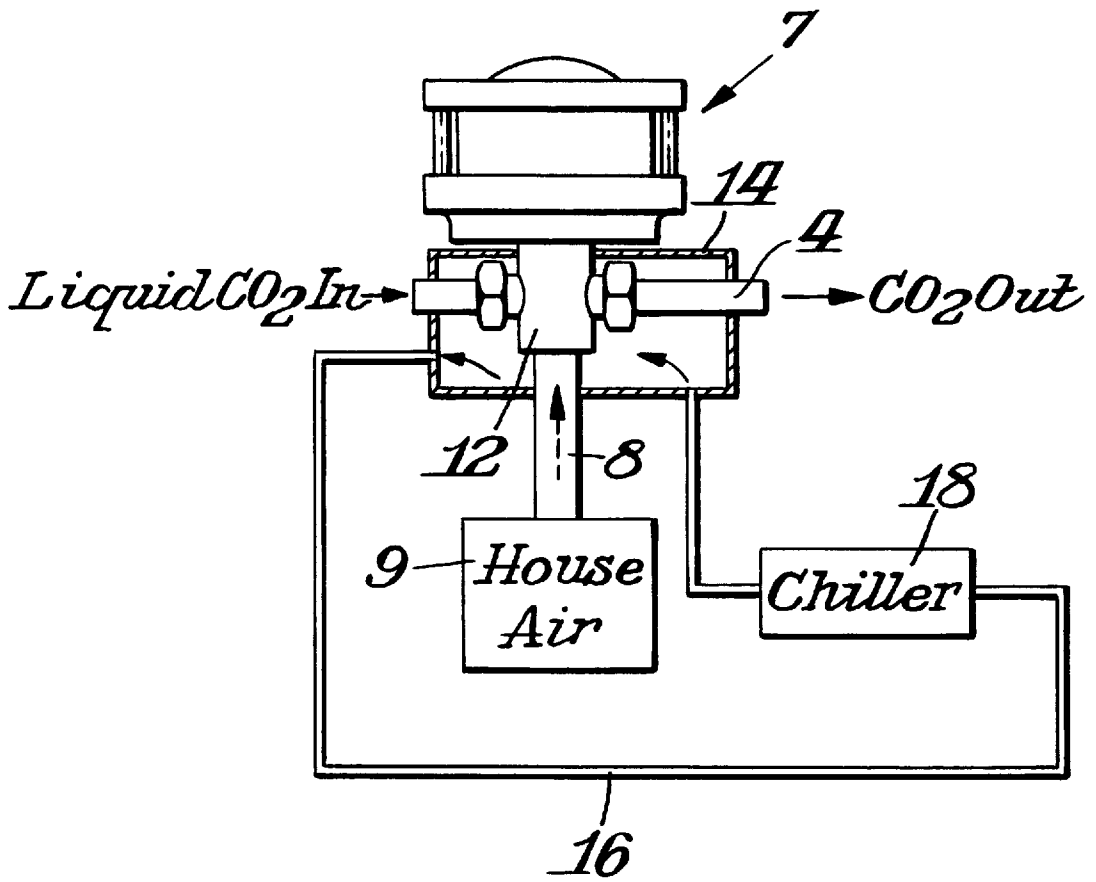

Fig. 2.



PRECISION HIGH PRESSURE CONTROL ASSEMBLY

CROSS-REFERENCE TO RELATED APPLICATION

This application is a continuation-in-part of application Ser. No. 08/739,893 filed Oct. 30, 1996, now U.S. Pat. No. 5,797,719.

BACKGROUND OF THE INVENTION

The present invention relates to improved assembly or system for the control of a pump to increase and closely maintain the desired pressure for a supercritical fluid.

The critical point for a substance is the temperature and pressure where the liquid and vapor phases exist in equilibrium. Above the critical point, the supercritical range, the vapor will have the high densities of a liquid but the diffusion coefficient of a vapor. The vapor looks like a "gas" but acts like a "liquid" and is called a supercritical fluid which has the superior dissolving and extracting properties of a liquid.

Supercritical fluids may function as a superior media for chemical reactions. Once a supercritical reaction is complete the fluid is vented to leave just the reaction product. Supercritical fluid reactions offer enhanced reaction rates and selectivity. Additionally, supercritical fluids technology may be used for chromatography and infusion as well as close pressure control or processing within the supercritical range.

Various attempts have been made to provide controls for supercritical fluids. For example, U.S. Pat. No. 4,684,465 relates to an apparatus for analyzing a process stream via supercritical fluid chromatography wherein the monitoring and control functions are related to controlling the flow rate. The '465 patent is an auto sampler which uses only one pump cycle and thus does not involve a continuous flow.

SUMMARY OF THE INVENTION

An object of this invention is to provide a system or assembly for sensing the desired supercritical fluid substance pressure and closely control the process pump to maintain the desired pressure thus providing enhanced properties for a specific application.

An assembly for the successful application of this technology is the accurate sensing of pressure, which feeds a signal to a process controller with an electric signal output. The output electrical signal from the process controller provides the input signal to an electropneumatic regulator which is used to control the drive pressure to a positive displacement pump, for example a piston driven pump which is preferably in a chill housing. For the CO₂ system, the process input to the pump is liquid CO₂ at 800–1,000 psi, and output pressure from the pump may be up to approximately 10,000 psi.

The unique assembly and programming of the downstream pump discharge pressure sensor, process controller, electronic signal controller output, and electropneumatic pressure regulator control valve have enhanced the useful application of supercritical fluid technology.

THE DRAWINGS

The FIG. 1 is a schematic representation of a preferred embodiment of the invention; and

FIG. 2 is an elevation view, partially in section of the piston driven pump shown schematically in FIG. 1.

DETAILED DESCRIPTION

FIG. 1 illustrates a preferred embodiment of this invention. As shown therein, the assembly of this invention is utilized for the handling of CO₂. A source 10 of liquid CO₂ would be provided with the liquid CO₂ at low pressure of about 800–1,000 psi. The CO₂ would be fed to a pump 7 and discharged from the pump through outlet line 4.

Pump 7 functions to compress the CO₂ whereby the high pressure creates a supercritical fluid. Pump 7 may be of any suitable construction, as later described, and preferably is a piston driven pump mounted in a cold or chill housing.

The pressure of the CO₂ in outlet line 4 is sensed by a suitable pressure sensor 3 which accurately monitors the desired high pressure (critical fluid) of the CO₂.

Pressure sensor 3 provides an input signal 2 to process controller 1. Process controller 1, in turn, yields a control output signal 5 to an electropneumatic regulator 6. Regulator 6 controls the pump 7 to compress the CO₂ fed from reservoir 10. Thus, the pump 7 transfers the CO₂ from the reservoir 10 and elevates and maintains the desired supercritical fluid pressure. In this manner, liquid CO₂ in reservoir 10 is fed under low pressure such as about 800–1,000 psi to pump 7 and is discharged in outlet line 4 under high pressure of, for example, 800–20,000 psi.

In operation, air such as house air at a pressure of about 100 psi is fed from a conventional compressor 9 and is closely controlled to become the regulated driver air 8 at pressures ranging from 0 to full 100 psi pressure and then to the pump 7. The high pressure in outlet line 4 is monitored by pressure sensor 3 to rapidly and continuously provide the input 2 to process controller 1. The control outlet signal 5 from process controller 1 sends an electronic signal back to the electropneumatic regulator 6 and the cycle is repeated. The cycle operates in a continuous manner and permits precise adjustments of the pressure resulting in outlet line 4.

An advantageous use of the invention would be to accurately program various pressure ramps and dwells within a tolerance of ± 1 psi. Parent application Ser. No. 739,893 (the details of which are incorporated herein) shows a comparison in FIG. 2 of that application of the accuracy in achieving ramps/dwells characteristics with use of the invention as contrasted to conventional prior art techniques.

Very close pressure control is thus the key to effectively achieving precise pressure-temperature ramping to effect solvent properties of a supercritical fluid for selective extraction of target compounds from a complex mixture. Accordingly, this technique provides a very cost effective and environmentally friendly alternative rather than the more traditional solvent extraction techniques for separation of mixtures.

By close control of pressure different components of a mixture may be solvated using either static extraction or dynamic extraction or a combination. By understanding the phase diagrams of the mixtures, pressure and temperature of the supercritical fluid may be controlled to select and analyze material of interest to be removed.

In general, lower temperatures and higher pressures are desired to avoid functionalizing, denaturing, or thermal transition.

It is to be understood that although the invention has been described with respect to the handling of carbon dioxide, the invention may also be used for other substances, including but not limited to propane, ethane, pentane, isobutane, ammonia, nitrogen, and various other fluorocarbons.

The following table lists the critical conditions for various solvents with which the invention could be practiced.

Solvents	Critical Temperature (°C.)	Critical Pressure (bar)
Carbon dioxide	31.1	73.8
Ethane	32.2	48.8
Ethylene	9.3	50.4
Propane	96.7	42.5
Propylene	91.9	46.2
Cyclohexane	280.3	40.7
Isopropanol	235.2	47.6
Benzene	289.0	48.9
Toluene	318.6	41.1
p-Xylene	343.1	35.2
Chlorotrifluoromethane	28.9	39.2
Trichlorofluoromethane	198.1	44.1
Ammonia	132.5	112.8
Water	374.2	220.5

The invention overcomes limitations of the prior art by offering a 200-fold improvement in the control of pressure in the 800 to 20,000 psi range. The control systems offered by the prior art would frequently result in pump output pressure several orders of magnitude greater than the target pressure, thus yielding the application of the technology to be either inefficient or inapplicable.

The use of the invention permits higher flow rates to the order, for example, of 19 liters per minute in contrast to the prior art flow rates which are only micro liters per minute. Accordingly, the practice of the invention permits flow rates having several orders of magnitude greater than with the prior art. A range of flow rate possible with the present invention is 0.0001–19 liters per minute.

The invention may be used in various processes. Reference is made to U.S. Pat. No. 5,269,930, the details of which are incorporated herein by reference thereto, which relates to collecting analyte in a supercritical fluid extraction process. The invention may be used, for example, in such a process.

As previously pointed out the invention permits the precise monitoring and control of pressure in the continuous system. A typical control range for the pressure in outlet 4 by use of the invention is 800–20,000 psi with the preferred range being 1,000 to 10,000 psi.

Any suitable equipment may be used for the components in the practice of this invention. For example, microprocessor 1 may be a PLC direct, DL405 series PLC comprised of a DL-440 CPU (no. D4-440), a 4-Channel Analog Input Module (D4-04AD) and a 2-Channel Analog Output Manual (D4-02AD). The pressure sensor 3 may be a Pressure Transducer which could be a Setra pressure transducer, part no. 280111-10 psig. The pressure controller could be an air valve/volume booster which is a Proportion—Air, part no. QB1TFIE100/PSR-2. Suitable components such as described in U.S. Pat. No. 4,684,465 (the details of which are incorporated herein) may also be used as part of the assembly or system of this invention.

FIG. 2 illustrates the preferred form of pump 7. As shown therein the pump 7 is in the form of a piston driven pump 12 which could be of known construction such as a commercially available Haskel air driven liquid pump. As illustrated in FIG. 2 liquid CO₂ would enter the pump housing 12 and would exit the pump housing through outlet line 4. Air, such as house air, from compressor 9 would become the regulated driver air 8.

In accordance with this invention the pump chamber 12 is mounted in a chill can 14 through which is circulated a cryogenic such as ethylene glycol which is at a temperature, for example, -10° C. to -15° C. The cryogenic circulates

through line 16 between the cryogenic source 18 and chill can or cryogenic chamber 14. Chill can 14 is made of any suitable transfer heat material to function as a cryogenic chamber. The provision of the cryogenic chamber increases the pump efficiency by keeping the pump head cold. This solves the problem of pump cavitation with liquid gases which would tend to flash when hitting a warm pump. Thus, flash and cavitation is prevented or at least minimized by the arrangement shown in FIG. 2.

What is claimed is:

1. A precision high-pressure control assembly for supercritical fluids comprising a continuous flow system having a pressure control loop which includes a source of fluid, said source of fluid communicating with a pump head of a piston driven pump for compressing the fluid and increasing the pressure of the fluid to create a supercritical fluid, an outlet line leading from said pump head, a pressure sensor monitoring the pressure of the supercritical fluid in said outlet line, a process controller having an input for receiving a signal relating to the pressure sensed by said pressure sensor, said process controller yielding an electronic control output signal to a regulator, a source of air communicating with said regulator to provide pressurized regulated driver air directed to said pump, said regulator controlling the regulated driver air pressure of said pump in accordance with the signal received from said process controller, and said pump head being in a cryogenic chamber for minimizing flash and cavitation.

2. The assembly of claim 1 including a source of cryogenic, and a circuit connected to said cryogenic chamber and said source of cryogenic for circulating a cryogenic medium therebetween.

3. The assembly of claim 2 wherein said regulator is an electropneumatic regulator.

4. The system of claim 1 wherein said fluid is carbon dioxide.

5. The system of claim 1 wherein said fluid is selected from the group consisting of propane, ethane, pentane, isobutane, ammonia, nitrogen and fluorocarbons.

6. A method for close pressure control of a supercritical fluid comprising feeding a fluid under low pressure to the pump head of a piston driven pump, increasing the pressure of the fluid by the pump wherein the fluid is discharged to an outlet line as a supercritical fluid under high pressure, sensing the pressure of the supercritical fluid in the outlet line by a pressure sensor which provides an input signal to a process controller with the input signal being reflective of the amount of pressure being sensed, sending an electronic control output signal from the process controller to a pressure regulator, supplying air from an air source to the pressure regulator to provide pressurized regulated driver air directed to the pump, controlling the regulated driver air pressure of the pump by the pressure regulator in accordance with the signal received by the pressure regulator from the process controller, and minimizing flash and cavitation by locating the pump head in a cryogenic chamber.

7. The method of claim 6 wherein the fluid is carbon dioxide.

8. The method of claim 6 wherein the fluid is selected from the group consisting of propane, ethane, pentane, isobutane, ammonia, nitrogen and fluorocarbons.

9. The method of claim 6 wherein the pressure in the outlet line is in the range of 800–200,000 psi.

10. The method of claim 6 wherein the pressure is controlled to accurately obtain at least one ramp and one dwell of high precision.

11. The method of claim 10 wherein a plurality of ramps and dwells are obtained.

5

12. The method of claim **10** wherein the pressure is controlled to an accuracy of ± 1 psi.

13. The method of claim **11** wherein the method is used as pressure-temperature ramping to effect solvent properties of the supercritical fluid for selective extraction of target compounds.

6

14. The method of claim **6** wherein the fluid flows from the pump at a flow rate of from 0.0001 to 19.0 liters per minute.

* * * * *